

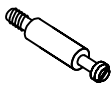











Thank you for purchasing the Performance False Pedestal.  
Please follow these instructions for easy assembly.

1  Cam Lock 10 Pcs	2  Klix Cam 10 Pcs	3  Housing Cap 10 Pcs	4  6 Hole L-Bracket 4 Pcs	5  Screw #6 x 5/8" 24 Pcs	6  Adjustable Glide 3 Pcs
7  Ø8mm Hole Plug 3 Pcs	8  D-Nut Cap M6 2 Pcs	9  M4 x 65 Allen-Key 1 Pc	10  JCBC Bolt M6 x 40mm = 2pcs Washer = 4pcs		

A  Side Panel	B  Top Panel	C  Bottom Panel	D  Side Panel	E  Front Panel
--	---	--	---	---

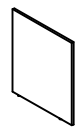
**KLIX CAM INSTRUCTIONS**

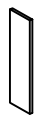
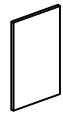
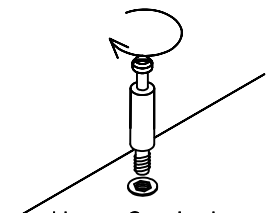
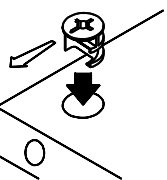
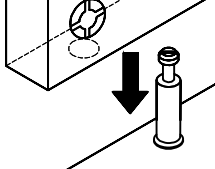
1  Line up Cam Lock, turn clockwise.	2  Insert the cam with the arrow pointing towards the hole in the edge.	3  Insert the Cam Lock into Klix Cam. Turn Klix Cam to lock.
---	---	---

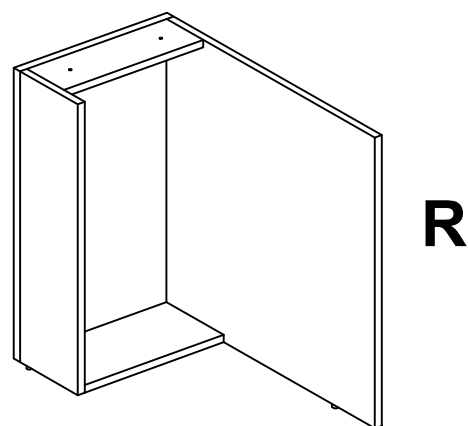
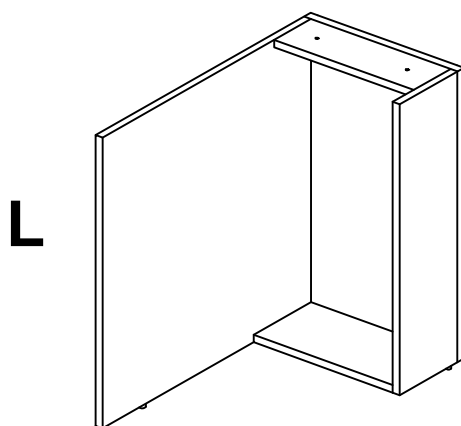

**IMPORTANT !!**

- Place all wooden parts on a clean and smooth surface such as a rug or carpet to avoid the parts from being scratched.
- Check that you have all parts and hardware.
- Remove all wrapping materials, including staples & packing straps before you start to assemble.
- Do not tighten any screws or bolts until the unit is completely assembled.
- Keep all hardware parts out of reach of children.

**1**

Attach Top Panel (B) & Bottom Panel (C) to Side Panel (A) & Side Panel (D) by using Cam Lock (1) and Klix Cam (2).

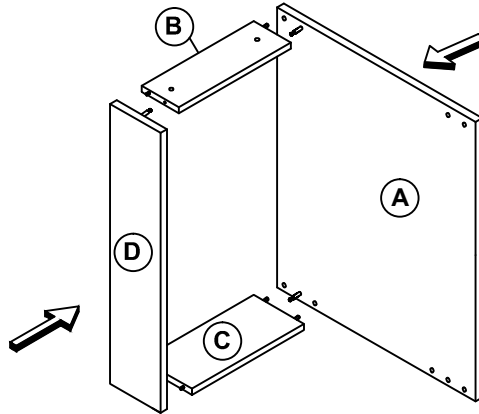

**2**

Attach Front Panel (E) to Side Panel (A) & Side Panel (D) by using Cam Lock (1) and Klix Cam (2).

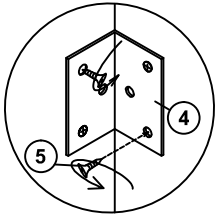

Attach L-Bracket (4) to Front Panel (E) and Side Panel (A) / Side Panel (D) with screw (5).

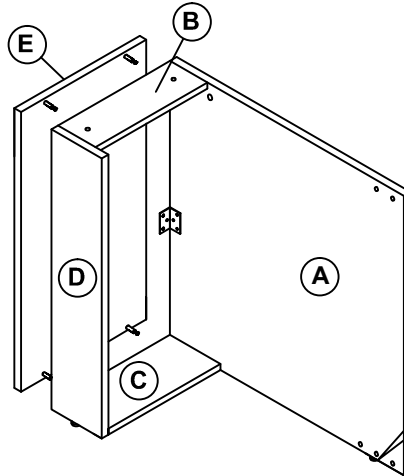

Screw Adjustable Glide (6) into bottom of Side Panel (A) & Side Panel (D).

**3**

worksurface

Mount False Pedestal to underside of worksurface by using JCBC Bolt (10).  
\*JCBC Bolt with 2 washers per bolt

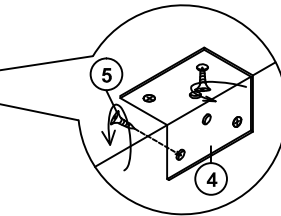
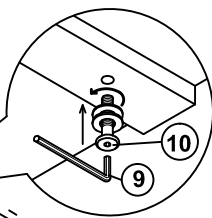

Attach L-Bracket (4) to worksurface and Side Panel with screw (5).

Attach False Pedestal to worksurface by using Cam Lock (1) and Klix Cam (2).

**4**

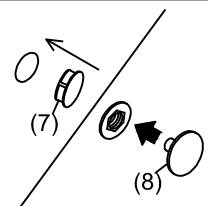

Insert the Hole Plug (7) and D-nut Cap (8) to all drill hole of the other edge of Side Panel (A) which the hole are not in use.

**5**

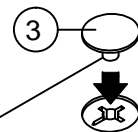

Attach Housing Cap (3) to all Klix Cam (2) by pushing neck through center of cam.