

# ASSEMBLY INSTRUCTIONS

## MODEL: PLTVALEGMOUNT3642

Before assembly, please remove all parts from the carton, verifying that you have the correct quantities, and read all the instructions.  
**\*\*Please Note: When attaching the metal legs to the laminated tops, installed D-Nut holes are to be used as a guideline only for installation, wood screws need to be attached as well, whenever they are provided. Not all of the provided holes on these metal legs will line up with the inserts on the laminated tops. The provided wood screw may also need to be used\*\***

### INSTRUCTIONS:

### IN THE CARTON:

#### STEP 1

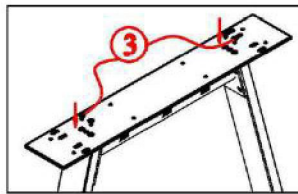
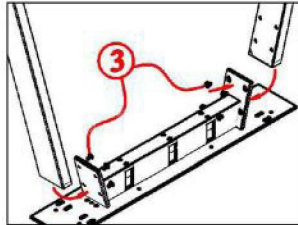
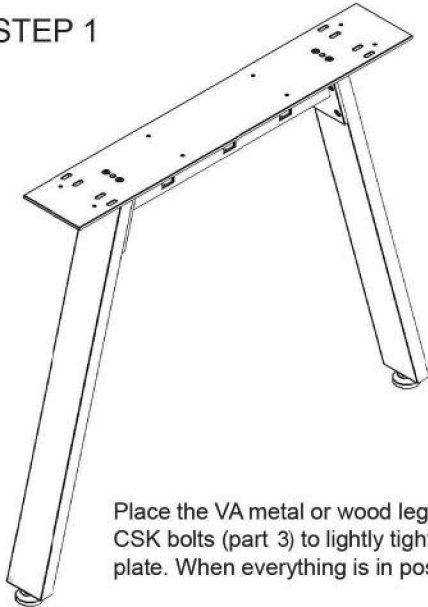

Place the VA metal or wood leg on the top mount plate, and use CSK bolts (part 3) to lightly tighten the VA leg to the top mount plate. When everything is in position, then screw in the bolts tightly.

#### Leg Parts List

1		Allen Key	1 pc
2		Wood Screw x 20 mm	8 pcs
3		CSK Bolt M6 X 20	12 pcs
4		Jam Screw	6 pcs
5		Bolts M6 x 16mm	2 pcs
6		Ø17MM Flat Washer	2 pcs
7		Spacer	5 pcs

#### SOLD SEPARATELY: PLTMAINDESKBEAM

#### Main Desk Beam Parts List

8		Wood Screw x 20 mm	4 pcs
9		CSK Bolt M6 X 16mm	1 pcs
10		Bolts M6 x 12mm	12 pcs

#### STEP 2

1. Place table tops upside down on a clean surface
2. PLBE/PLT table tops are used for several applications, and have many metal inserts. Only two of these inserts are used for the PLTVALEG. These inserts are the "A2" inserts, as per the PLT instructions.

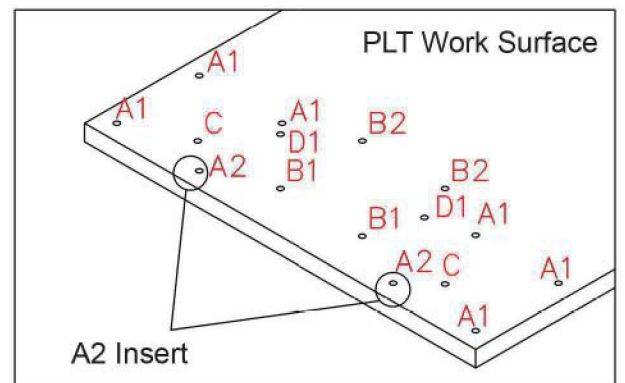

#### STEP 3

3. If you are using a 36" top, you need to align the "E" hole on the VA leg with the A2 insert.  
If using a conference tabletop, see conference table instructions.
4. Screw the two bolts (part 5) with washer (part 6) into the metal inserts referred to step 3.

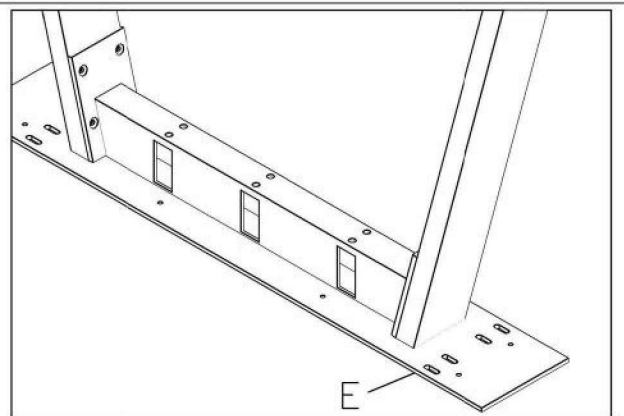

# ASSEMBLY INSTRUCTIONS

## MODEL: PLTVALEGMOUNT3642

### STEP 4

5. Slide the metal desk beams slightly through the opening found at the top of the VA legs
6. Fasten the second leg to the top, following step 3
7. Center the desk beam so that it is placed evenly through the openings of both VA legs

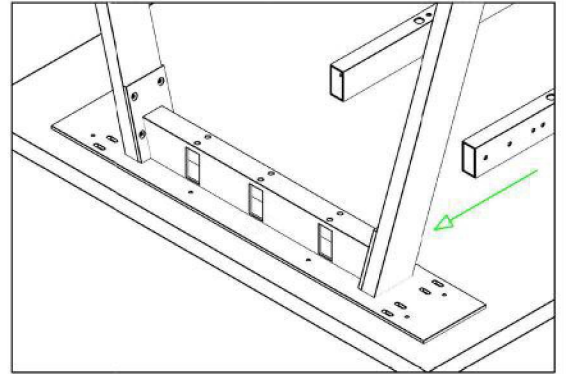

### STEP 5

8. Tighten the desk beam to each VA leg by using two of the jam screws (part 4) and Allen Key (part 1).
9. Depending the length of the desk beam, there are either two or three holes through the beam to the work surface. Place one spacer (part 7) between the beam and the work surface under each hole. Attach the main beam to the work surface using wood screws (part 8).
10. Use wood screws (part 2) to attach the leg to the work surface.

**Note:** The wood screw pack is inside the beam.

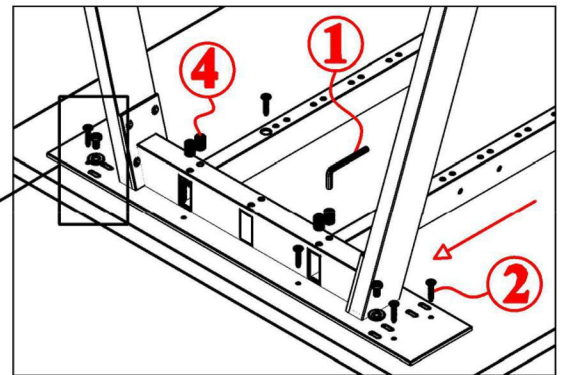
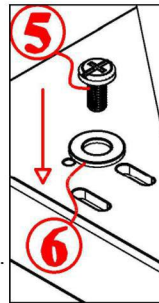

Extra parts are packed. You may have some left over.

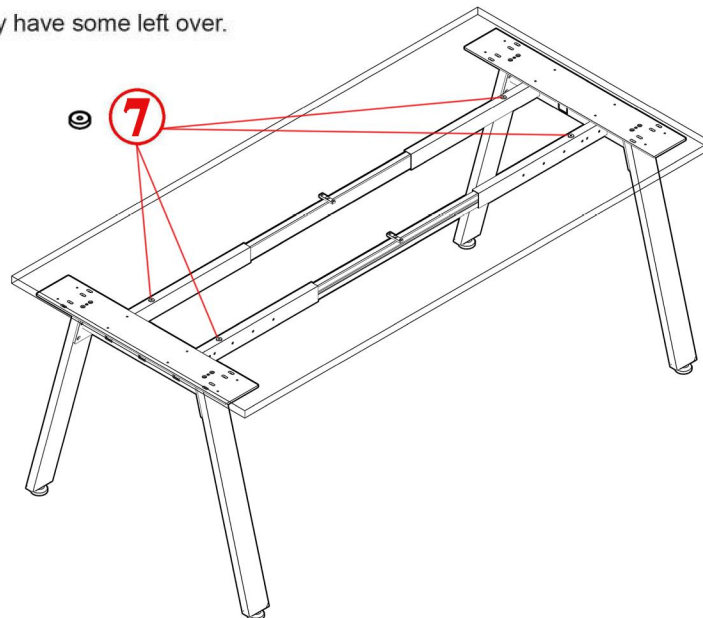

### ⚠ ATTENTION ⚠

Do not tighten any screws or bolts until the unit is completely assembled.

Ensure all bolts and screws are tightened before using the table, check bolts and screws every 6 months.

If any parts are missing, broken, damaged or worn, stop use of product until repairs have been made using factory authorized parts.

Failure to follow these warnings may result in injury.