

ASSEMBLY INSTRUCTIONS

MODEL:

PLTWMBASE-1818+2424+2448+3030+3636



PERFORMANCE
FURNISHINGS

Before assembly, please remove all parts from the carton, verifying that you have the correct quantities, and read all the instructions.

INSTRUCTIONS:

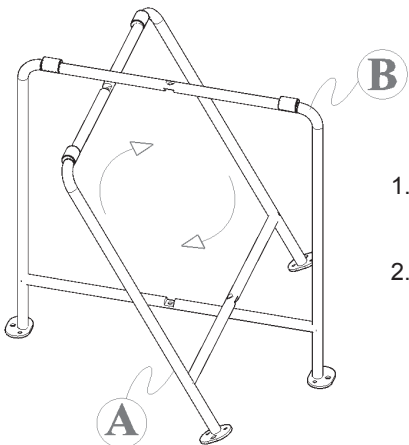

B

1. Slide part A into part B, while in a slanted position.
2. Rotate part A to fit into the center slot of part B.

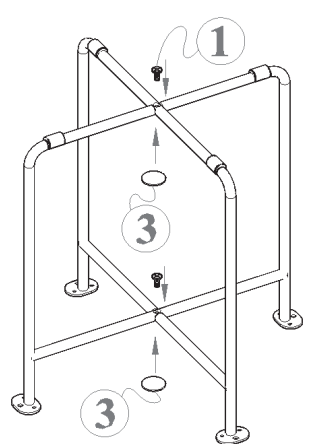

1

3

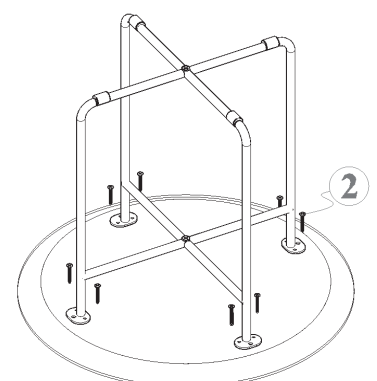

3. Screw in two M6 screws, at the center of the top and bottom. Cover screw holes, with stickers provided to hide the opening.



2

4. Place the table top upside down on a clean surface. Place the legs on the underside of the table top. Screw in eight screws, to join the legs with the top.

IN THE CARTON:

(1)	(2)	(3)
		
M6 - 2 pcs	Screws - 8 pcs	Stickers - 2 pcs

INSTRUCTIONS for GLASS TOP:

Glass top includes 4 suction cups.

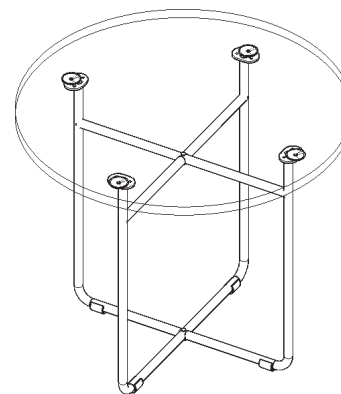
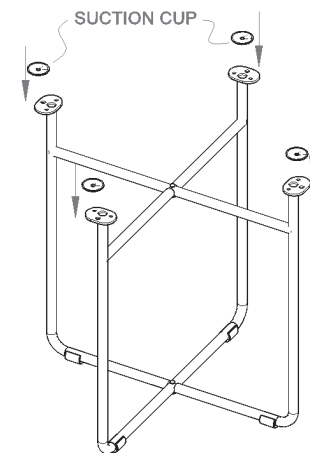

⚠ ATTENTION ⚠

Do not tighten any screws or bolts until the unit is completely assembled.

Ensure all bolts and screws are tightened before using the table, check bolts and screws every 6 months.

If any parts are missing, broken, damaged or worn, stop use of product until repairs have been made using factory authorized parts.

Failure to follow these warnings may result in injury.